

Main characteristics

- Absolute measurement of position and speed
- Possibility of one or two cursors simultaneously
- Local intelligence
- Interface: CANopen DS-301 V4.01 Device Profile DS-406 V2.0
- Strokes from 100 to 4000 mm
- Position resolution up to $2\mu\text{m}$
- Speed resolution up to 0.01 mm/sec
- Linearity error $\leq 0.01\%$
- Repeatability error $\leq 0.001\%$
- Conforms to EC directives (EN 50081-2 50082-1)
- Resistance to vibrations (DIN IEC68T2/6 12g)
- IP67 protection

Absolute linear position transducer, contactless for long mechanical life. Magnetostrictive technology for highest resolution and repeatability. The sealed IP67 structure makes the sensor suitable for use in hostile environments.

The MK2 CANopen integrates a microprocessor to process the measurement and to diagnose the transducer. The CAN field bus communication system provides fast and safe transmission. The use of CANopen DS-301 protocol and Device Profile DS-406 provides quick and easy integration of the transducer in the control and automation system.

TECHNICAL DATA

| | |
|-----------------------------|------------------------------------------------|
| Model | from 100 to 4000 mm |
| Measurement taken | linear position and speed |
| Position read sampling time | from 1 to 4 ms (depending on length) |
| Shock test DIN IEC68T2-27 | 100g - 11ms - single blow |
| Vibration DIN IEC68T2-6 | 12g / 10...2000Hz |
| Sliding cursor drag force | $\leq 1\text{ N}$ |
| Shift speed | $\leq 10\text{ m/s}$ |
| Max. acceleration | $\leq 100\text{ m/s}^2$ shift |
| Resolution | $5\mu\text{m}$ ($2\mu\text{m}$ on request) |
| Cursor | Floating ring with integrated magnets |
| Rated power supply | 24Vdc $\pm 20\%$ |
| Max. power ripple | 1 Vpp |
| Max. input | 100mA typical |
| Output signal | CAN bus digital communication |
| Electrical isolation | 500V (D.C. power/ground) |
| Reverse polarity protection | YES |
| Overvoltage protection | Varistors on power line |
| Overcurrent protection | PTC (self-resettable fuse on power line) |
| Environmental protection | IP67 |
| Work temperature | $-40\dots+70^\circ\text{C}$ |
| Storage temperature | $-40\dots+100^\circ\text{C}$ |
| Coefficient of temperature | Typical $20\text{ ppm}/^\circ\text{C}$ |

MECHANICAL DIMENSIONS

Version MK2C B/M with sliding magnetic cursor

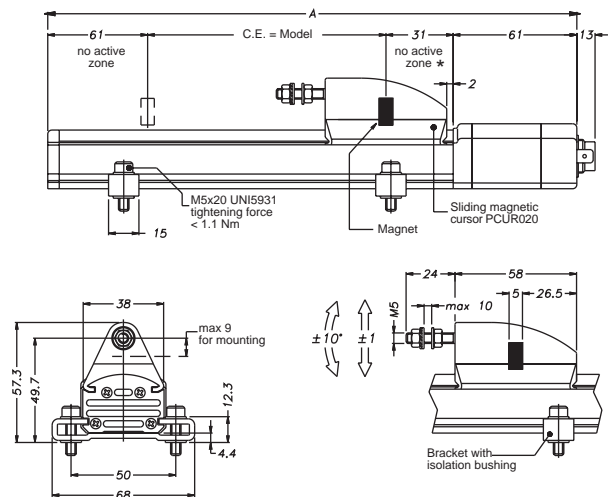

Version MK2C F with floating magnetic cursor

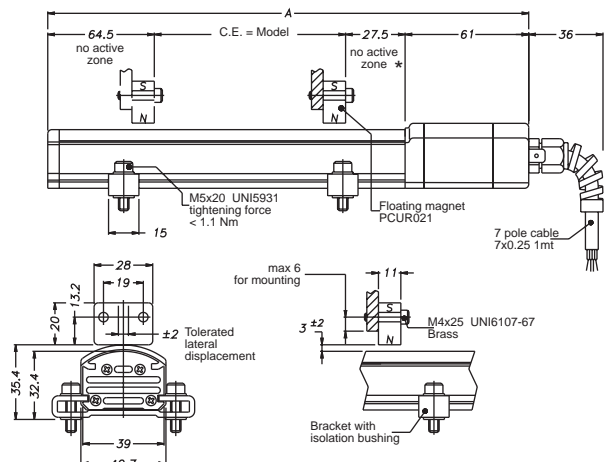

* For the models from 2000 in then, to increase the quota 20mm.

ELECTRICAL/MECHANICAL DATA

| | | | | | | | | | | | | | | | | | | | | | | | | | | | | | | | | |
|--------------------------|-----|-------------------------------------------|-------|-----|-----|-----|-----|-----|-----|-----|-----|-----|-----|-----|-----|------|------|------|------|------|------|------|------|------|------|------|------|------|----------------|--|--|--|
| Model | | 100 | 130 | 150 | 200 | 225 | 300 | 400 | 450 | 500 | 600 | 700 | 750 | 800 | 900 | 1000 | 1250 | 1500 | 1750 | 2000 | 2250 | 2500 | 2750 | 3000 | 3250 | 3500 | 3750 | 4000 | | | | |
| Electrical stroke (C.E.) | mm | Model | | | | | | | | | | | | | | | | | | | | | | | | | | | | | | |
| Independent linearity | ± % | 0,03 | 0,025 | | | | | | | | | | | | | | | | | | | | | | | | | | ≤ 0,02 of C.E. | | | |
| Max. dimensions (A) | mm | Modello + 153 (+173mm. from 2000 in then) | | | | | | | | | | | | | | | | | | | | | | | | | | | | | | |
| Repeatability | ± % | 0,001 of C.E. | | | | | | | | | | | | | | | | | | | | | | | | | | | | | | |
| Hysteresis | mm | < 0,01 | | | | | | | | | | | | | | | | | | | | | | | | | | | | | | |

ELECTRICAL CONNECTIONS

| | | | | | | |
|---------------------|---------------------|---------------------|-----------------|------------------------------|------------------------------|-------------------------------|
| OUTPUT MK2CB | OUTPUT MK2CM | OUTPUT MK2CF | Function | Connect. (B) Pin° | Connect. (M) Pin° | Cable (Wire Color) |
| | | | CAN L | 1 | 5 | Blue |
| | | | CAN H | 2 | 4 | White |
| | | | n.c. | 3 | 1 | - |
| | | | n.c. | 4 | - | - |
| | | | Power + Vdc | 5 | 2 | Red |
| | | | DC Ground | 6 | 3 | Black |

ATTENTION! Do not connect the DC Ground to the ground or to the cable sheathing.

ORDER CODE

Position transducer **MK2** **C**

| | |
|---------------------------------------|----------|
| CANopen interface | C |
| 6-pin DIN 45322 output connector | B |
| 5-pin Micro type M12 output connector | M |
| 4-pin braided cable (on request) | F |

Model

Type (see table 1)

Transmission speed (see table 2)

| Type | No. Cursors | PD01 (Standard) | PD02 (Standard) |
|----------|-------------|---------------------------------------------------------------------|---------------------------------------------------------------------|
| A | 1 | Position 4 Byte whole Speed 2 Byte whole Cams 1 Byte whole | Absence of data |
| B | 2 | Position 1, 4 Byte whole Speed 2 Byte whole Cams 1 Byte whole | Position 2, 4 Byte whole Speed 2 Byte whole Cams 1 Byte whole |

| 1 = 1MBaud | 4 = 250 kBaud | 7 = 50 kBaud |
|---------------|---------------|--------------|
| 2 = 800 kBaud | 5 = 125 kBaud | 8 = 20 kBaud |
| 3 = 500 kBaud | 6 = 100 kBaud | 9 = 10 kBaud |

Mechanical and/or electrical characteristics differing from those in the standard version may be arranged on request.

Ex.: **MK2-C-B-0400-A-3 0000-2-XXXX-00-X-0-XX**
 Transducer model MK2, CANOpen output, connector B, model 400, type A (one cursor), transmission speed 500 Kbaud.

► **Included in the supply**

- Series MK position transducer
- Fastening brackets with insulating bushes and screws

Magnetic cursors must be ordered separately

- Sliding magnetic cursor code: **PCUR020**
- Floating magnetic cursor code: **PCUR021**

CODE EXTENSION

| | | | | | | | | | | | | | | | |
|--------------------------|--------------------------|--------------------------|--------------------------|--------------------------|--------------------------|-------------------------------------|-------------------------------------|-------------------------------------|-------------------------------------|--------------------------|--------------------------|-------------------------------------|--------------------------|-------------------------------------|-------------------------------------|
| <input type="checkbox"/> | <input type="checkbox"/> | <input type="checkbox"/> | <input type="checkbox"/> | <input type="checkbox"/> | <input type="checkbox"/> | <input checked="" type="checkbox"/> | <input checked="" type="checkbox"/> | <input checked="" type="checkbox"/> | <input checked="" type="checkbox"/> | <input type="checkbox"/> | <input type="checkbox"/> | <input checked="" type="checkbox"/> | <input type="checkbox"/> | <input checked="" type="checkbox"/> | <input checked="" type="checkbox"/> |
|--------------------------|--------------------------|--------------------------|--------------------------|--------------------------|--------------------------|-------------------------------------|-------------------------------------|-------------------------------------|-------------------------------------|--------------------------|--------------------------|-------------------------------------|--------------------------|-------------------------------------|-------------------------------------|

System resolution

1 = 0.002 mm
 2 = 0.005 mm (standard)
 3 = 0.010 mm
 4 = 0.020 mm
 5 = 0.040 mm

Node number programmer

XXX = standard; node = 127
 nnn = Node number specified in order

Cable length

Output **F** 00 = 1mt 02 = 2mt 03 = 3mt 04 = 4mt 05 = 5mt
 Output **B** 00 06 = 6mt
 Output **M** 00

Termination load

0 = without termination load
 1 = 120Ω termination load

Transmission speed as function of cable length

| Cable length | Baud Rate (Kbaud) | Cable length | Baud Rate (Kbaud) |
|--------------|-------------------|--------------|-------------------|
| < 25 m | 1000 | < 500 m | 125 |
| < 50 m | 800 | < 1000 m | 100 |
| < 100 m | 500 | < 1250 m | 50 |
| < 250 m | 250 | < 2500 m | 20 / 10 |

Can Open Data Protocol

| SOFF | Arbitration | Control | Data Field | CRC | ACK | EOF | Interframe Space |
|------|-------------|---------|------------|-------------|-----|-----------|------------------|
| 1 | 11 | 1 | 6 | 0 - 8 Bytes | 15 | 1 1 1 | ≥ 3 Bits |

GEFRAN spa reserved the right to make aesthetic or functional changes at any time and without notice.

GEFRAN spa
 via Sebina, 74
 25050 PROVAGLIO D'ISEO (BS) - ITALIA
 ph. 0309888.1 - fax. 0309839063
 http://www.gefran.com

GEFRAN

DTS_MK2Can_1006_ENG